

# PARAPAN® Quote Request/ Order Form

Fax completed form  
to: (704) 332-3267

Request for:  Quote  Order

Company: \_\_\_\_\_  
 Contact Name: \_\_\_\_\_  
 Address: \_\_\_\_\_  
 City, State, Zip: \_\_\_\_\_  
 Phone #: \_\_\_\_\_  
 Fax #: \_\_\_\_\_  
 Email: \_\_\_\_\_



Date: \_\_\_\_\_

PO Number (if applies): \_\_\_\_\_

**AF006 Aluminum Frames with PARAPAN® Inserts**

AF006  AF006S

All AF Series profiles available with PARAPAN 4mm Inserts: see AF door order form

4mm Insert Color for AF006/AF006S or 18mm Solid High Gloss Doors

- |  |   |  |
|--|---|--|
| <input type="checkbox"/> 5910 - alpine white | <input type="checkbox"/> 5773 - cappuccino  | <input type="checkbox"/> 5776 - brown      |
| <input type="checkbox"/> 5907 - white        | <input type="checkbox"/> 5570 - orange      | <input type="checkbox"/> 5299 - black      |
| <input type="checkbox"/> 5196 - opal white   | <input type="checkbox"/> 5771 - oxide red   | <input type="checkbox"/> 5295 - stone grey |
| <input type="checkbox"/> 5772 - latte        | <input type="checkbox"/> 5655 - signal red  | <input type="checkbox"/> 5290 - light grey |
| <input type="checkbox"/> 5525 - pale ivory   | <input type="checkbox"/> 5380 - cobalt blue | <input type="checkbox"/> 5297 - anthracite |
| <input type="checkbox"/> 5510 - corn yellow  | <input type="checkbox"/> 5440 - kiwi        | (5297 available in 18mm only)              |

**Door Fabrication:**

- No Fabrication  
 Hinge (Only) Borings  
 Handle (Only) Borings  
 Handle & Hinge Borings

**18mm PARAPAN® Doors**

High gloss, reflective solid surface doors, repairable, easy to clean, UV & fade resistant, waterproof, no VOCs

**18mm Door Edge: (2mm edge detail standard)**

- Straight Edge  
 1mm Edge Radius  
 2mm Edge Radius  
 3mm Edge Radius

**Acrifix™ PARAPAN® Cleaner**  
(one complimentary 4oz. bottle supplied with order)

Include Additional Cleaner:  4 oz. Qty. \_\_\_\_\_  
 16 oz. Qty. \_\_\_\_\_

**Include Hinges:**  
(Attachment screws will be provided based on quantity of doors/drawers)

no  
 yes Qty. \_\_\_\_\_

**Handles/Knobs:**

no  
 yes Qty. \_\_\_\_\_  
 Part #: \_\_\_\_\_

Item	Quantity	Door / Drawer / Panel Dimensions (WIDTH x HEIGHT)	in./mm select one	Left (L), Right (R), Up (U) Drawer Front (D), or Panel (P) select one	# Hinge Borings	Notes
1				<input type="checkbox"/> L <input type="checkbox"/> R <input type="checkbox"/> U <input type="checkbox"/> D <input type="checkbox"/> P		
2				<input type="checkbox"/> L <input type="checkbox"/> R <input type="checkbox"/> U <input type="checkbox"/> D <input type="checkbox"/> P		
3				<input type="checkbox"/> L <input type="checkbox"/> R <input type="checkbox"/> U <input type="checkbox"/> D <input type="checkbox"/> P		
4				<input type="checkbox"/> L <input type="checkbox"/> R <input type="checkbox"/> U <input type="checkbox"/> D <input type="checkbox"/> P		
5				<input type="checkbox"/> L <input type="checkbox"/> R <input type="checkbox"/> U <input type="checkbox"/> D <input type="checkbox"/> P		
6				<input type="checkbox"/> L <input type="checkbox"/> R <input type="checkbox"/> U <input type="checkbox"/> D <input type="checkbox"/> P		
7				<input type="checkbox"/> L <input type="checkbox"/> R <input type="checkbox"/> U <input type="checkbox"/> D <input type="checkbox"/> P		
8				<input type="checkbox"/> L <input type="checkbox"/> R <input type="checkbox"/> U <input type="checkbox"/> D <input type="checkbox"/> P		
9				<input type="checkbox"/> L <input type="checkbox"/> R <input type="checkbox"/> U <input type="checkbox"/> D <input type="checkbox"/> P		
10				<input type="checkbox"/> L <input type="checkbox"/> R <input type="checkbox"/> U <input type="checkbox"/> D <input type="checkbox"/> P		
11				<input type="checkbox"/> L <input type="checkbox"/> R <input type="checkbox"/> U <input type="checkbox"/> D <input type="checkbox"/> P		
12				<input type="checkbox"/> L <input type="checkbox"/> R <input type="checkbox"/> U <input type="checkbox"/> D <input type="checkbox"/> P		
13				<input type="checkbox"/> L <input type="checkbox"/> R <input type="checkbox"/> U <input type="checkbox"/> D <input type="checkbox"/> P		
14				<input type="checkbox"/> L <input type="checkbox"/> R <input type="checkbox"/> U <input type="checkbox"/> D <input type="checkbox"/> P		
15				<input type="checkbox"/> L <input type="checkbox"/> R <input type="checkbox"/> U <input type="checkbox"/> D <input type="checkbox"/> P		

**OPTIONAL**  
 4mm PARAPAN® decorative and appliance panels:  
 yes - code: \_\_\_\_\_  
 (rough or finished dimensions listed)

Quantity	Panel Dimensions (WIDTH x HEIGHT)	in./mm select one

Quantity	Panel Dimensions (WIDTH x HEIGHT)	in./mm select one

# Hinge and Handle Specs

Line Item # \_\_\_\_\_ (from pg 1)

Please make copy and fill out 1 sheet for each different boring pattern

## Hinge Borings

X1 = \_\_\_\_\_ (std=7/8") OR B/T = \_\_\_\_\_ (std=5 mm)

X2 TOP/LEFT = \_\_\_\_\_ (minimum = 3")  
(std = 3 1/2")

X2 BOTTOM/RIGHT = \_\_\_\_\_ (minimum = 3")  
(std = 3 1/2")

X3 = \_\_\_\_\_ (optional)

X4 = \_\_\_\_\_ (optional - not shown)

X5 = \_\_\_\_\_ (optional - not shown)

## Handle Borings

K1 = \_\_\_\_\_ (Knob or Pull)  
(Min = 2 1/4") (Std = 2 1/2")

K2 = \_\_\_\_\_ (Knob or Pull)  
(Std = centered on frame)

K3 = \_\_\_\_\_ (Pull only)  
(center to center distance)

Handle Hole Diameter = 11/64"

Contact Element Designs for special hardware borings (e.g. lift-up systems)

## Hinge Boring Spec

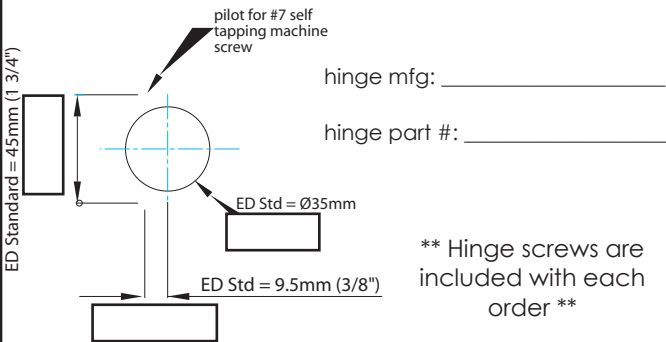

## BACK OF DOOR/ DRAWER FRONT SHOWN

